

EMCS-512 Ceiling Speaker



Features

- > Voltage 100V, 1~6W with multiple terminals, suited for different field
- > Max. Sound Pressure Level 99 ± 2 dB, Effective Freq. Range 100Hz ~ 16kHz
- > Weight 0.4 kg Equipped with clamps for mounting
- > Made of high quality engineering plastic, long-term durability, never out of shape and colour never fade
- > Driver surround excellent damping, provided with high sensitivity (91 ± 2 dB), long life, clear and sonorous sound

Model	EMCS-512
Speaker Size	4.5"
Input Power (Tappings)	6W / 3W / 2W / 1W
Line Voltage	70-100V
Sensitivity (1m, 1W)	91dB
Max Sound Pressure Level (1m)	97dB
Frequency Response	100Hz - 16KHz
Hole for Mounting	$\phi 170$ mm
Dimensions	110 x $\phi 180$ mm
Weight	0.4kg

Dimensions

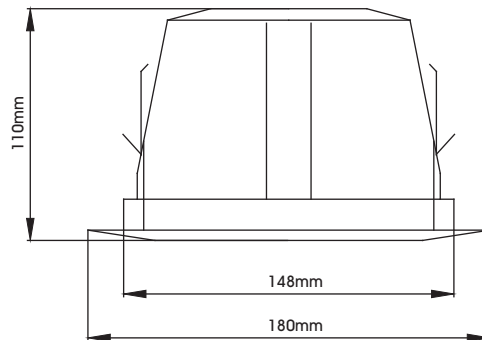

Installation

