



Public Address System

Wall Mount Speaker System EMWS-331B



OWNER'S MANUAL

Thank you for purchasing PA speaker system of EMIX series. All of EMIX series products have been tested strictly before shipping. EMIX series PA speaker system is widely used in hotel, trade building, supermarket, school, entertainment, etc. It's the most ideal choice of you! In order to facilitate installing, modulating and running please read this manual carefully before setup.

FEATURES:

- The wall mount speaker is suitable for different public address wires. It can be switched between the ohms terminal and the voltage terminal.
- Rated power 20W .Max. Sound Pressure Level $102 \pm 2\text{dB}$, Effective Freq. Range 80Hz - 20kHz;
- Weight 2.2kg, equipped with hanging holes for mounting ;
- It is made of high quality engineering plastic, long-term durability, never out of shape and fade;
- With high sensitivity speaker unit $89 \pm 2\text{dB}$, long life, sounds clear and sonorousness.

FREQ. RESPONSE

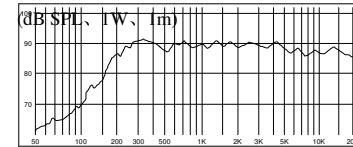

DISTORTION

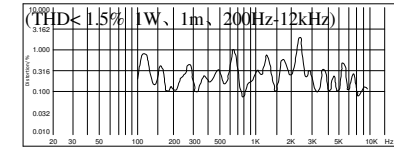

INSTALLATION DIAGRAM

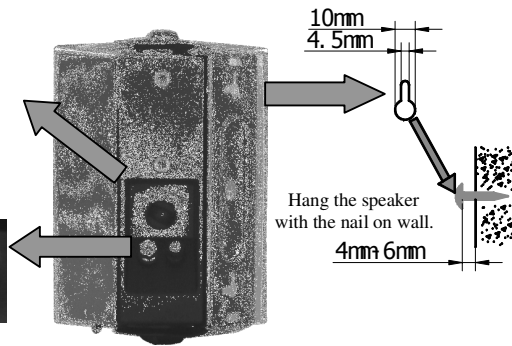
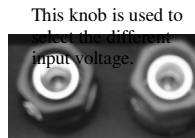
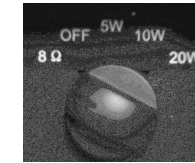

Connect public address wire to these two terminals.

Warning: DO NOT switch the knob to the low impedance terminal (8 Ω) when the speaker is connected with amplifier's high impedance output terminal (100V), otherwise the speaker will be damaged!